

Lites

HPLED II T (tunable)

Owner's and service manual

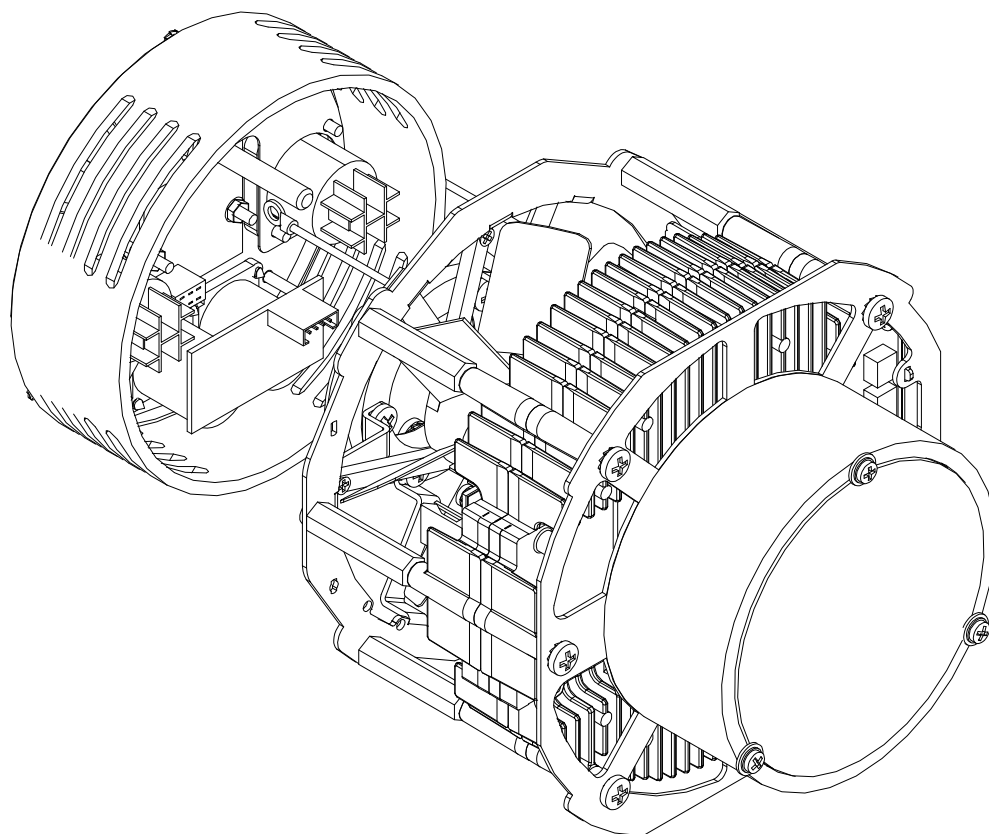

Read this manual totally and carefully follow all the instructions contained. File this manual for future use

It is essential to read all the information contained to ensure correct installation, service and full operation of the HPLED II

All operations must be accomplished, handled and carried out by qualified personnel only

NOT COMPLYING WITH GIVEN NOTICE IT WILL VOID WARRANTY AND WILL FREE THE MANUFACTURER OF ANY KIND OF RESPONSIBILITY AND LIABILITY.

www.litessrl.com

Unpacking

Unpack the carton and gently remove HPLED II T from the box. Ensure HPLED II T is received in all its parts.

In the event the HPLED II shows any damage, do not use it and contact immediately your transporter as well as your seller

Items in the carton consist of:

HPLED II T Module

Rear metal cover with input connections

Blue Neutrik PowerCon connector

This owner's manual

Safety information for the use of the HPLED II and periodical maintenance of unit.

Users must scrupulously comply with information/indications that follows

HPLED II T must be installed on original " **ETC source 4**" fixture only. Any other use will void warranty and will free the manufacturer of any sort of responsibility and liability.

Never utilise HPLED II T assembly alone as it must always be housed in original ETC Source 4 barrel.

Minimum distance from any flammable source is of 0.25m.

Minimum throw distance from illuminated surface: 0.5m.

Installation of the unit(s), including external source4 body, must be secured with adequate clamps, safety cords, nuts and bolts to bear at least 4 times the weight of the whole unit(s)

Always Power HPLED II T to safety circuit breakers

Install HPLED II T in ventilated ambient which temperature must not exceed 35°C

HPLED II T is NOT for domestic use. HPLED II T can only be used for professional applications

Some outer parts of the ETC Source4 can reach temperatures of up to 60C° when HPLED II T is operated

HPLED II T must be fitted with protection shields (Lenses)

On no account, directly or indirectly, LED must be touched as it may impair its use.

An Essential and Periodically throughout cleaning of the HPLED II T is recommended. This practice avoids that layers of dust and other impurity jeopardise and reduce the correct operation of the unit. Lenses must be cleaned to remove layers of dust that may impede and or reduce the passage of the light through the lenses. The correct and periodically maintenance keeps also fans and vents clean thus keeping the HPLED II T in its best performance conditions. Never touch, directly or indirectly, the Yellow core of the LED nor use solvents that can damage the LED irremediably. Protection shields if battered/worn, must be replaced with new ones (Lenses)

Warning from electric shocks

All operations must be accomplished, handled and carried out by qualified personnel only

Warning High voltage hazard, always disconnect Power before any handling and any servicing of HPLED II

Do not and never handle HPLED II T with humid/wet hands or near to any water or any kind of moisture sources

Always connect HPLED II T to mains fitted with safety device switch that cuts power off in case of danger

The HPLED II T does NOT and CAN NOT be operated via Phase control dimmer nor connected/operated in NON-DiM mode

HPLED II T is rated Class I

Earth connection is mandatory!

CE Approvals

The HPLED II T products to which this manual refers to, complies with European directive pursuant to:

2014/35/EU safety of electrical equipment supplied at low voltage (LVD)

2014/30/EU Electromagnetic compatibility (EMC)

2011/65/EU Restriction of the use of certain hazardous substances (RoHS)

WARRANTY!

A 12-month warranty is granted on the HPLED II T from purchase's date. Warranty covers fabrication defects only.

Warranty is immediately voided if the HPLED II T has been handled by unqualified personnel. Any improper and unauthorised use, such modification(s) or misapplication of the HPLED II T will also void the warranty of the product(s). Silver colour label showing technical data and serial number, if removed or if data are impaired to render details illegible, it will immediately void the warranty

Technical specifications

Power Supply	100-240	V~ 50/60Hz
Maximum power consumption	170W	
Stand-by power consumption	5W	
Minimum ambient temperature	-10°C	
Maximum ambient temperature	35°C	
LED Colour Temperature:	3000°K-5700°K	
LED CRI	96 (3000°K) and 94 (5700°K)	
LED Life	(see Manufacturers ' specifications)	
Weight	2,49 Kg	
IP Rating	To be housed into original ETC Source four fixture only	
Working position	Any	
Power connectors	IN & OUT Neutrik PowerCon	
Data connectors	IN & OUT XRL5	
Data protocols	DMX 512; RDM ready	
User interface	4-digit display and 4 buttons	
Manual operation:	Users must operate via buttons provided on the display	
Fan control:	Fan speed adjustment	
Control of LED frequency:	Selection of LED frequency refresh	
2 Dimming curves control:	Selection of two dimming curves control	
CE compliant		
Dimensions (see picture)		

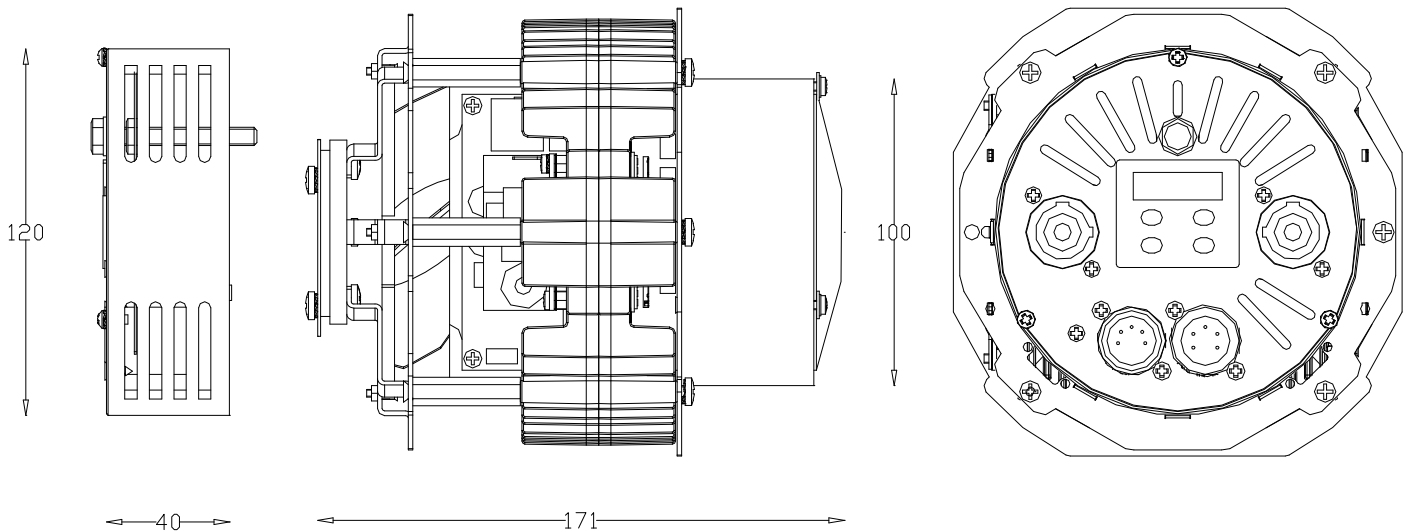

HPLLED IIT installation

HPLLED II T has been designed to be installed in any original "ETC source 4" fixtures. Some parts of the existing "ETC Source 4" fixture must be removed to lodge the module in

Course of actions:

1. **Disconnect any kind of power/source from any item being handled, that could cause electric shock**
2. Loosen knobs that hold front lens assembly, remove it and place it aside in a safe place
3. Locate rear section of the Source 4 fixture, then start loosening knob that holds the round plate in place until it is totally separated from the main body. You may either store or scrap this part. **HOWEVER LOCK-WASHER AND THE M4 SCREW USED TO HOLD THE GROUND CORD ON THE ETC SOURCE4 BODY MUST BE SECURED ASIDE AS THEY WILL BE USED FOR THE NEW GROUND CORD PROVIDED WITH THE HPLLED IIT FIXTURE.**
4. **As of now onwards for your own safety we recommend you must wear protection gloves and safety transparent eye protection goggles.**
 5. Locate the Source 4 inner reflector and start removing it (use the optional Lever if ordered with HPLLED II) from its housing as shown in the Source four assembly guide
6. Place HPLLED II T on working bench and start loosening the 3 M4 screws that hold the metal ring (marked by red arrow in figure 2).
7. Accommodate the HPLLED II in the Source4 body. Ensure the correct inward direction is followed as remarked by the 2-red-round ring references. Make also sure to follow the red arrow direction as shown in figure 3. During such operation make sure that the 3 connecting cables (i.e. power cable, DMX cable and display cable) are not squeezed, while being lead through loop-holes during reassembling of the unit.
8. Remount the metal ring to its former position; tighten now the 3 provided M4x6 screws to their full extent. Do not exceed nor force tightening.
9. Connect the 3 lead-cables to the rear metal cover provided, ensure that connectors are inserted in the correct side. Special attention must be paid to the **flat cable** as it must be handled with extreme care while connecting its ends. (if flat cable is squeezed or impaired it can cause malfunctionings to the product)
10. Ensure that all cable connections are neatly and clearly set to their positions avoiding any contact, interference, interconnections, interpositions with fans and other interfering components that might collide, squeeze hamper the correct operations and eventually damage the product.
11. Remount the rear metal cover to the Source 4 body using any 11mm spanner; tighten the screw to its full extent. Do not exceed nor force tightening.
12. The lock washer and the M4 screw used for holding the eyelet-cord to ground the fixture as expressed in point 3, must be now used to secure the new provided eyelet-cord to ground/earth the fixture as shown in fig.6

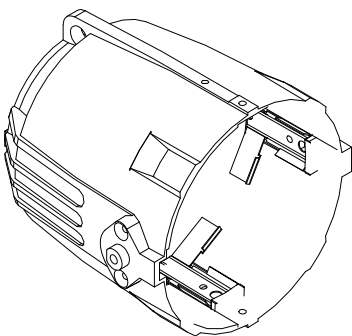

Fig.1

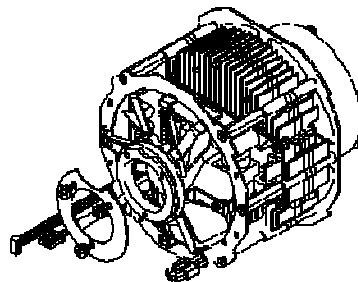

Fig.2

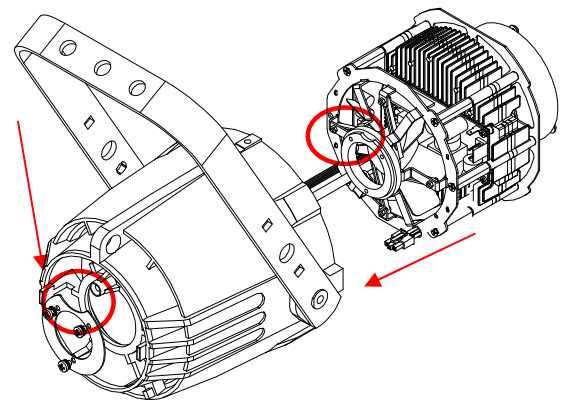

Fig.3

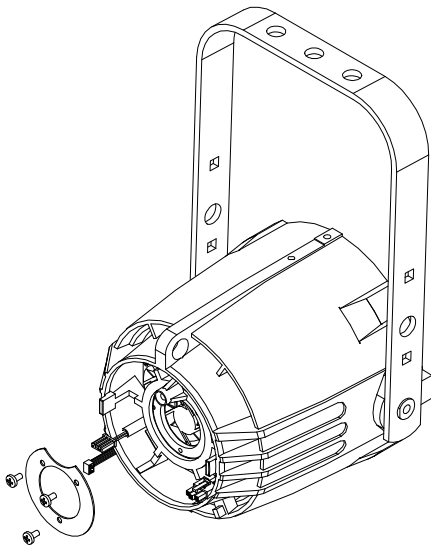

Fig.4

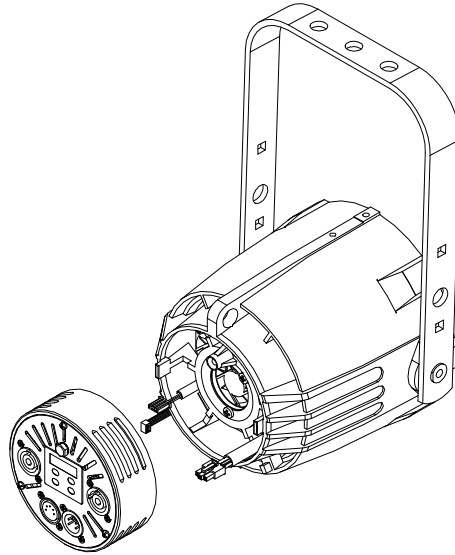

Fig.5

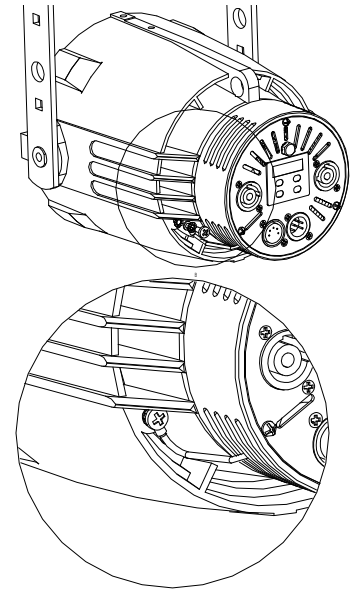

Fig.6

⚠ Connection to mains

WARNING ! Installation(s) must be accomplished, handled and carried out by qualified personnel only and must comply with all norms in force in the installation's country

HPLED II T is supplied with a free-Blue Neutrik PowerCon plug that must be wired using a 3x1.5mm² lead which additional specifications include:

Operating Voltage: 300/500V

Test Voltage: 2KV

Operating Temperature: -10°C / +90°C

Connect blue wire to N terminal, brown wire to L terminal and Yellow/Green wire to earth terminal. Ensure the use of safety circuit breaker at all times. Daisy chain of up to 10 units is permitted when connected to 230VAC. Daisy chain of up to 5 units is permitted when connected to 110VAC. Maximum daisy chain length: 20 m.

⚠ WARNING:NEVER CONNECT HPLED IIC5 ENGINE TO ANGLE PHASE DIMMER PACK NOR TO NON-DIM MODE

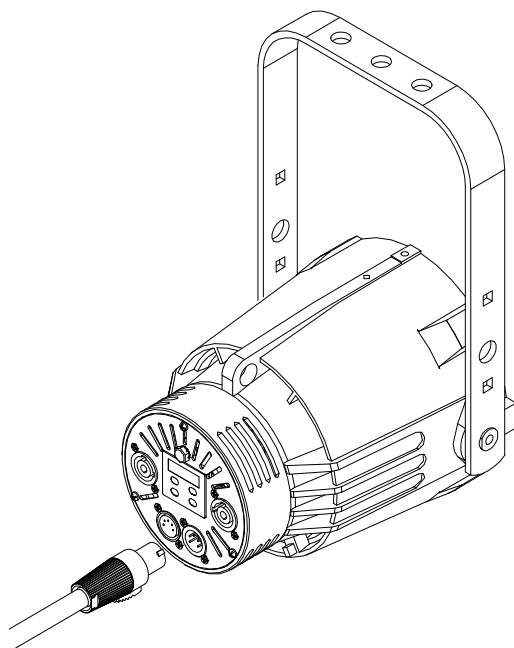

Fig.7

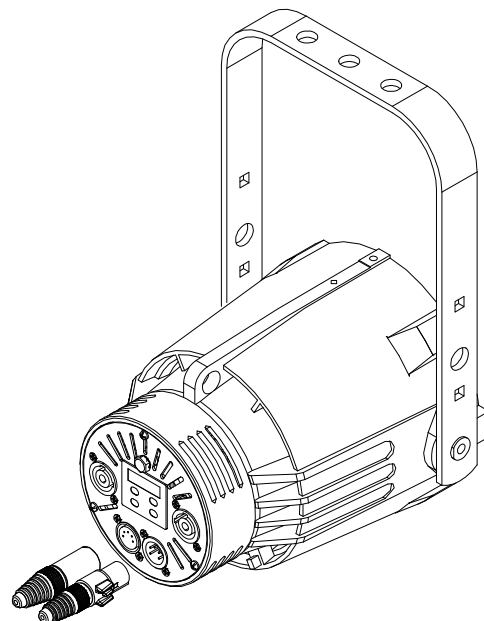

Fig.8

Signal control connection

HPLED II T can be operated via either DMX512A and or RDM ready Protocols. For Daisy chain DMX line use a-2 lead wire plus shield. Red led blinks when DMX Input is available. DMX off line when led is off

DMX XLR 5 Pin As sigment	
pin	Description
1	GND
2	DMX-
3	DMX+
4	Not connected
5	Not connected

RDM – Remote Device Management

RDM Controller allows for remote standard operations

RDM default options include:

Discovery mode: RDM is engaged when controller incepts this mode, the device reports itself by giving a flash of light (Controller sets the device in a listing to

read: settings, DMX address, personality settings, (Read all DMX mode including all DMX channels above)

ON/OFF "Identify": This mode is used to identify the manufacturer's device (Lites srl). It gives a flash of light from the LED

Model information (HPLED-dU)

Software version information (HPLED-dU v.x.xx)

Mode to reveal temperatures of the LED and of the driver

Mode to reveal hour-meters of the LED and of the device

Power HPLED IIT ON

WARNING ! Before powering HPLED IIT ensure that all installation(s) procedure(s) have(s) been properly set and accomplished.

When HPLED II T is powered the setup display will show the software release version. The UP, DOWN, ENTER and ESC buttons will allow for the operations of HPLED II T menu. UP and DOWN buttons allow to browse through menu options, the ENTER button is to confirm selection. The ESC button is to return to the previous menu or to quit previous setting (s).

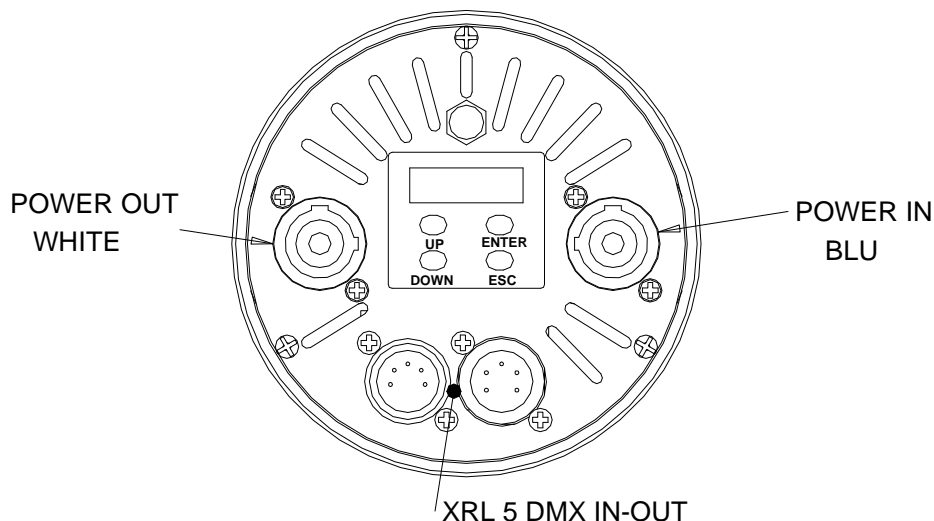

Menu items

Displayed Message	Allowed or displayed values	Function	
Addr	001..512	Set Up DMX Address	
Auto (Automatic mode)	co01 co02 co03 co04 co05 co06 co07 co08 co09 co10 co11 co12	Preset 1 White 3000°k Preset 2 White Preset 3 White Preset 4 White Preset 5 White Preset 6 White Preset 7 White Preset 8 White Preset 9 White Preset 10 White..... Preset 11 White Preset 12 White 5700°k	Values between co001 through co12 allow for fixed white set-up without DMX 512 protocol signal. When fixture is turned, the last selected preset will be held

	Pr01 Pr02	Program 1: auto Program 2 : auto	Automatic mode without DMX 512 Protocol signal. Program selections run between Pr01 through Pr 02 Both programs can be modified. To change program select Enter then view (Scn0...Scn9; max scenes of each program). Clicking on enter once more it shows P.00.0 (time) followed by F.00.0 (speed) and ultimately the last view shows 1c.01... though c12 (colour to be assigned to each scene) The use of UP/Down keys allow for setting values. When selections are completed press enter to confirm
MaSL		Master Mode The Master Mode uses the same settings as the Auto Menu. The only exception is that when all fixtures are connected to DMX 001 in daisy-chain, they perform the same presets and or the same presets selected on the Master fixture	
Mode	2 ch	3000/5700 °K	Dmx mode (view next page)
	2 ch (D)	3000/5700°K -dimmer (default)	
	3 ch	3000/5700°k-dimmer- strobo	
	4 ch	3000/5700°k-dimmer16(bit) strobe	
drUt	..°C	Shows driver operating temperature	
LEdt	..°C	Shows leds operating temperature	
PUM	0..100%	Shows current led power (0-100%)	
SMOO	FAST MED SLOW	DMX data Speed adjustment	
GAMM	LInE qUAd	Dimmer profile selection: - LinE for linear dimming regulation - qUAd for tungsten lamp emulation	
FREQ	1K 2K 3K 4K 5K 6K 7K 8K 9K 10K	LED operation frequency	
booS	Off on	When OFF, LED max flux : 90% When ON, LED max flux : 100%	
FAn	Aut MEDH MEDL LOW	4 fan operating modes i.e atuomatic, medium fast, medium slow, slow speed. Fan speed adjustments (fan-sound) reflect on self-correct output LED brightness and other factors as room-temperature, number of engaged channels	
PoS	AA VV	Display orientation selection: AA = normal VV = inverted	
StbY	Off on	Standby display activity: off = display always switched on = display switched off after few seconds of buttons inactivity (only the right side dot will be lighted to indicate DMX availability)	
dEF	Off on	ON Will restore the default factory values	
SoFt		Shows Software version	

DMX Operating Modes (Mode)

Selecting 1 of the 4 available modes it enables the number of channels required, and its relevant modes, needed to operate HPLED II T. **mode U2 ch white independent**

Ch	Function	dmx levels	
1	3000°k White	0..255	From 0 to max 255
2	5700°k White	0..255	From 0 to max 255

mode 2 ch (default)

Ch	Function	dmx levels	
1	3000°k-5700°k	0..255	When set to level 0 = 3000°k – When set to level 255 = to 5700°k
2	dimmer	0..255	From 0 to max 255

mode 3 ch dimmer

Ch	Function	dmx levels	
1	3000°k-5700°k	0..255	When set to level 0 = 3000°k – When set to level 255 = to 5700°k
2	dimmer	0..255	From 0 to max 255
3	shutter	0-15	Strobe disengaged
		16..255	Strobe from slow (16) to fast (255)

mode 4 ch dimmer 16 bit

Ch	Function	dmx levels	
1	3000°k-5700°k	0..255	When set to level 0 = 3000°k – When set to level 255 = to 5700°k
2	dimmer	0..255	From 0 to max 255
3	Dimmer fine	0..255	From 0 to max 255
4	shutter	0-15	Strobe disengaged
		16..255	Strobe from slow (16) to fast (255)

Error messages

In case of malfunction, the following messages can be shown:

HP Fan Error: means problems on fan

Temperature Error: LED sensor might be defective and or temperature has trespass threshold limit

Should any of the above given messages occur, the LED will automatically switch off. Refrain and halt the use of the HPLED II T and promptly contact any authorized service centre.

Periodical maintenance

To ensure the correct HPLED II T operation, we suggest the following periodical maintenance operations:

Remove dust or any kind of other dirt from the fans and loop-holes, this operation ensures the correct air flow. Remove dust from lenses using a clean cloth. This will ensure the maximum light efficiency

Replace damaged protection screen and lenses when necessary

Do not touch nor clean the LEDs nor the surrounding area with solvent

Device disposal information

At the end of its life, HPLED II T must be disposed to an appropriate electrical and electronic equipment waste collection centre. Eco-friendly disposal, helps to avoid possible negative impact on the environment and human health and promotes the reuse and/or recycling of the materials making up the product. Illegal disposal involves administrative sanctions provided by laws enacted.



Manufacture declines any sort of personal/corporate responsibility/liability for damages caused by people that are not scrupulously following indications given in this manual as for the inadequacy or for misuse of the product they do, as well as if the product has been handled by unqualified personnel. Not complying with security norms/periodical maintenance and all information contained and as expressed in the owner's/service manual will also totally free personal/corporate responsibility/liability. Text, wordings, drawings, specifications, modifications and other changes of this manual may apply anytime without notice. The specifications are not binding.